



TECHNICAL CATALOGUE

---

# SELF-CLEANING STRAINER

SELF-CLEANING  
STRAINER

SUITABLE FOR DOMESTIC  
WATER SERVICES, HEATING AND  
AIR-CONDITIONING PLANTS,  
COMPRESSED AIR SYSTEMS.

STRAINERS

# 189

## SELF-CLEANING STRAINER



SIZE	PRESSURE	CODE	PACKING
1/2" (DN 15)	16bar/232psi	1890012	1/9
3/4" (DN 20)	16bar/232psi	1890034	1/9
1" (DN 25)	16bar/232psi	1890100	1/6
1"1/4 (DN 32)	16bar/232psi	1890114	1/6
1"1/2 (DN 40)	16bar/232psi	1890112	1/5
2" (DN 50)	16bar/232psi	1890200	1/5

### TECHNICAL SPECIFICATIONS

Supplied with an extractable straining cartridge, double pressure gauge and hose cock to dump the impurities.

Body in nickel-plated brass.

Minimum and maximum working temperatures:

-20°C, 110°C in absence of steam.

**Filtration degree: 300µm.**

Threads: ISO228

(equivalent to DIN EN ISO 228 and BS EN ISO 228).

### MATERIALS

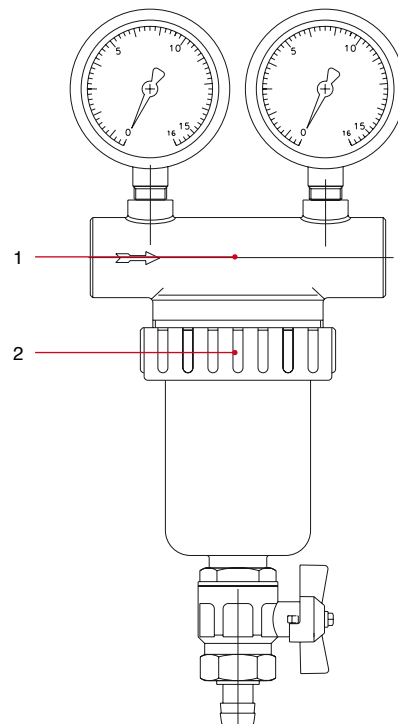

POS.	DESCRIPTION	N.	MATERIAL
1	Body	-	Nickel-plated brass CB735S EN 1984
2	Nut	-	Nickel-plated brass CW617N
-	Cartridge	-	Stainless steel AISI 304
-	Cartridge seats	-	NBR
-	O-Ring	-	NBR
-	Plastic parts	-	Ultramid®

OVERALL DIMENSIONS

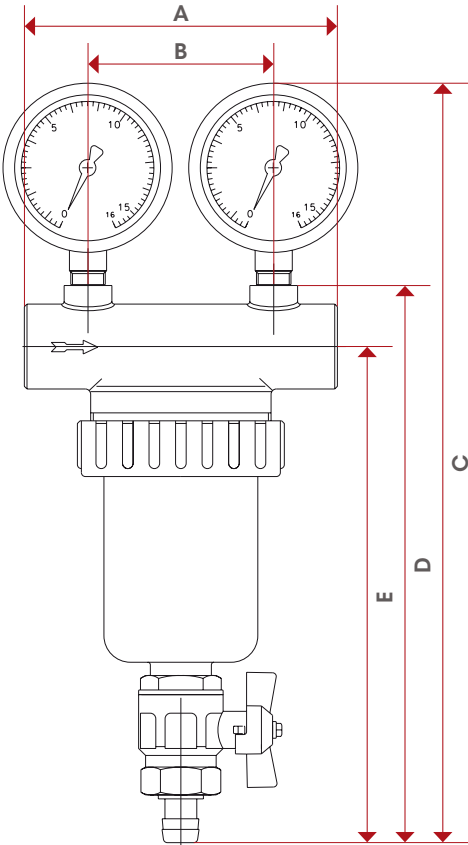

	1/2"	3/4"	1"	1 1/4"	1 1/2"	2"
A	118	118	123	123	153	153
B	70	70	72	72	98	98
C	272	272	302	302	342	342
D	208	208	234	234	272	272
E	187	187	202	202	236	236
Kg/cm <sup>2</sup> bar	16	16	16	16	16	16
LBS - psi	232	232	232	232	232	232

CERTIFICATIONS



STRAINERS

# FLOW RATE AND PRESSURE DROP CHART

WITH WATER

Art: 189

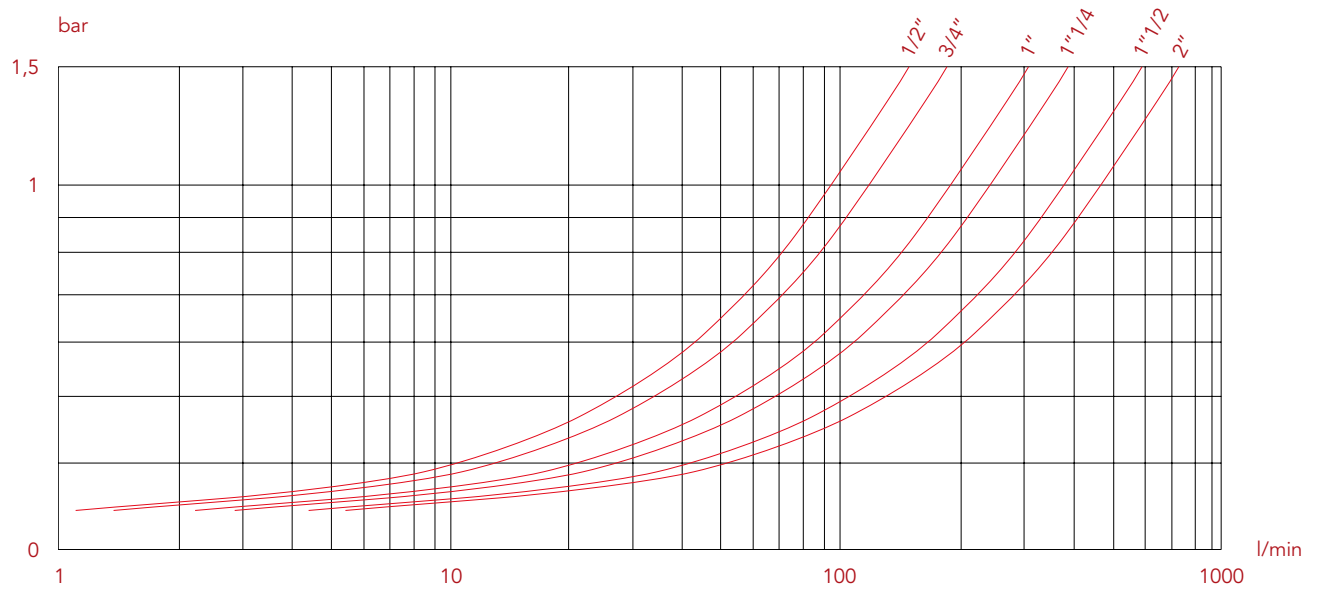

# SFS189

CARTRIDGE FOR SELF-CLEANING STRAINER  
ART.189



SIZE	CODE	FOR STRAINER
1/2" (DN 15)	189CA012	1/2"
3/4" (DN 20)	189CA034	3/4"
1" (DN 25)	189CA100	1"
1"1/4 (DN 32)	189CA114	1"1/4
1"1/2 (DN 40)	189CA112	1"1/2
2" (DN 50)	189CA200	2"

TECHNICAL SPECIFICATIONS

Filtration degree: 300µm

MATERIALS

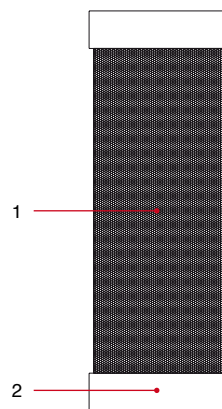

POS.	DESCRIPTION	N.	MATERIAL
1	Cartridge	-	Stainless steel AISI 304
2	End ring	-	NBR

OVERALL DIMENSIONS

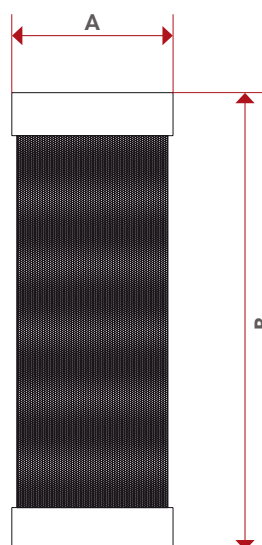

	1/2"	3/4"	1"	1"1/4	1"1/2	2"
DN	15	20	25	32	40	50
A	34	34	42	42	46	46
B	100	100	108	108	128	128