

## klepp *Edelstahlkugelhahn KHN7211H*



### TECHNISCHE DATEN

Innengewinde [thread]: EN10226

Mat.: 1.4408 / PTFE

Druck [Pressure]: PN63

Temp.: -20°C - +200°C

Lieferbar [Available]: DN8 – DN80

Baulänge [length]: DIN3202/4-M3

### Druck [Pressure] [bar]

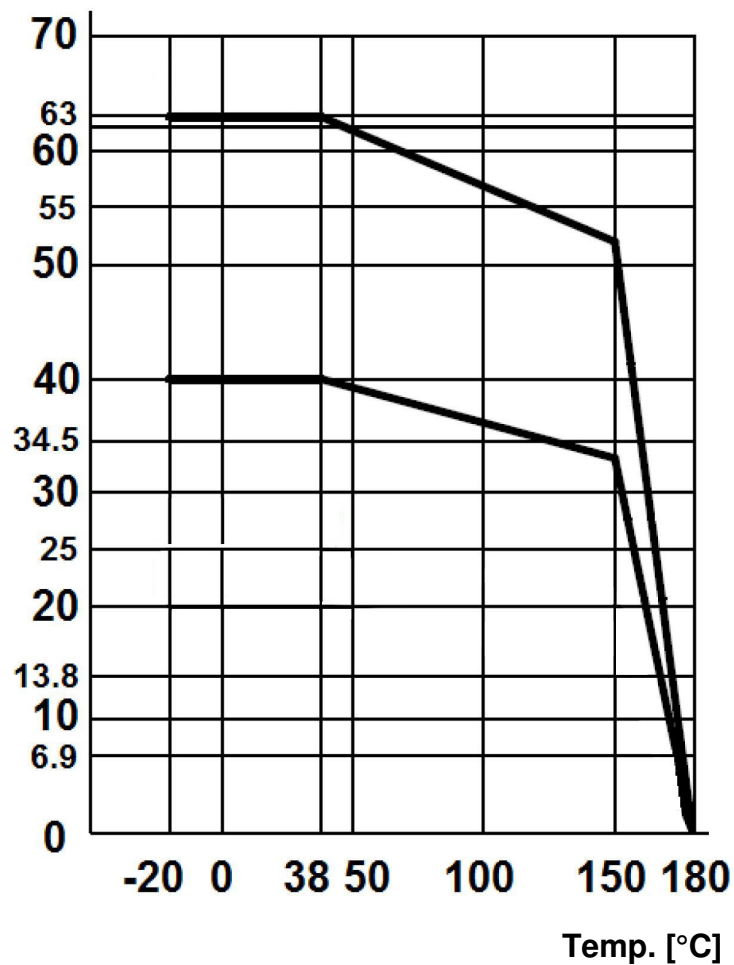

**KHN7211H**

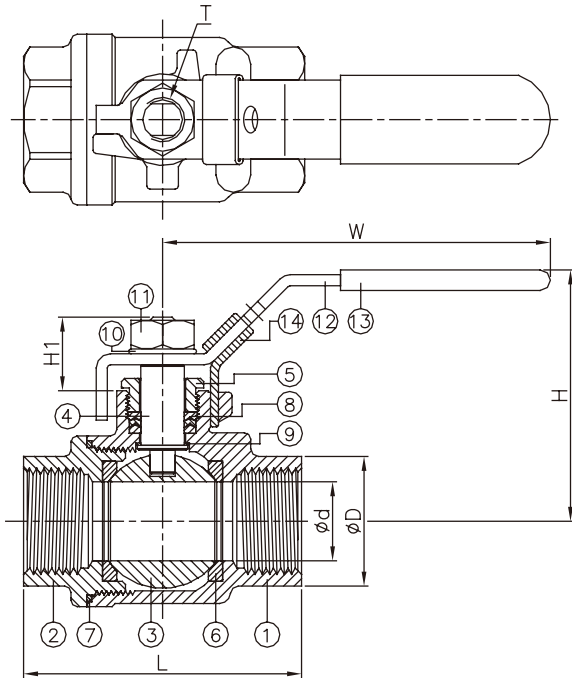

ITEM	PARTS	MATERIAL
1	BODY	ASTM A351-CF8M ASTM A216-WCB
2	CAP	
3	BALL	ASTM A351-CF8M
4	STEM	ASTM A276-316
5	GLAND	AISI 304
6	SEAT	PTFE / RTFE
7	SEAL	PTFE
8	PACKING	
9	THRUST WASHER	AISI 304
10	SPRING WASHER	
11	NUT	STAINLESS STEEL
12	HANDLE	
13	HANDLE SLEEVE	PVC
14	LOCKING DEVICE	AISI 304

DN	d	D	L	H	H1	T	W	Torque (N-m)	Weight (kg)
8	11.6	19	55.0	58.5	18	3/8"-24UNF	100	3.5	0.2
10	12.5	22.5	60.0	58.5	18	3/8"-24UNF	100	4	0.2
15	15	26	75.0	58.5	18.5	3/8"-24UNF	100	5.5	0.3
20	20	32	80.0	63.5	22.5	7/16"-20UNF	125	7.5	0.5
25	25	38	90.0	78	25	7/16"-20UNF	149	11	0.8
32	32	48	110	83	26	7/16"-20UNF	149	15	1.1
40	38	54.8	120	102	30	1/2"-20UNF	190	20	1.8
50	50	67	140	108	30	1/2"-20UNF	190	40	2.7
65	63	85	185	138	40	3/4"-10UNF	250	60	5.6
80	76	100	205	146	40	3/4"-10UNF	250	85	7.5

unit:mm

NPS	d	D	L	H	H1	T	W	Torque (in-lb)	Weight (lb)
1/4"	0.46	0.75	2.17	2.3	0.71	3/8"-24UNF	3.94	31	0.5
3/8"	0.49	0.89	2.36	2.3	0.71	3/8"-24UNF	3.94	35.4	0.5
1/2"	0.59	1.02	2.95	2.3	0.73	3/8"-24UNF	3.94	48.7	0.7
3/4"	0.79	1.26	3.15	2.5	0.89	7/16"-20UNF	4.92	66.4	1
1"	0.98	1.5	3.54	3.07	0.98	7/16"-20UNF	5.87	97.4	1.7
1-1/4"	1.26	1.89	4.33	3.27	1.02	7/16"-20UNF	5.87	132.8	2.5
1-1/2"	1.5	2.16	4.72	4.02	1.18	1/2"-20UNF	7.48	177	3.9
2"	1.97	2.64	5.51	4.25	1.18	1/2"-20UNF	7.48	354	5.9
2-1/2"	2.48	3.35	7.28	5.43	1.57	3/4"-10UNF	9.84	531	12.4
3"	2.99	3.94	9.45	5.75	1.57	3/4"-10UNF	9.84	752.3	16.5

unit:in