

RÜCKSCHLAGKLAPPE RVN8007



FEATURES

- 1/2"~3" (DN15~DN80)
- W.P. : PN16
- W.T. : -20°C~200°C (-4°F~392°F)
- Investment casting
- Socket weld (option)

- Thread type : ISO7/1 & EN10226

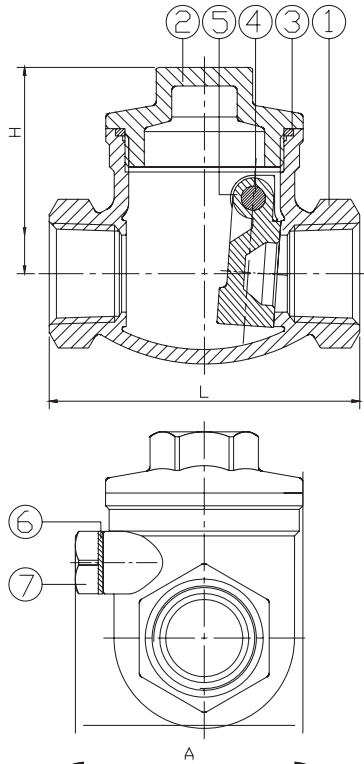

ITEM	PARTS	MATERIAL
1	BODY	ASTM A351-CF8M
2	CAP	
3	SEAL	PTFE
4	PLUG	AISI 316
5	DISC	ASTM A351-CF8M
6	GASKET	PTFE
7	BOLT	AISI 304

DN	L	H	A	Weight (kg)
15	65	44	46.5	0.4
20	80	52	52	0.4
25	89	62	56	0.7
32	105	67	65	0.9
40	120	79	75	1.5
50	139	80	84	2.2
65	181	96	108	5.3
80	200	104	137	7.7

unit:mm

NPS	L	H	A	Weight (lb)
1/2"	2.56	1.73	1.83	0.8
3/4"	3.15	2.05	2.05	0.9
1"	3.5	2.44	2.2	1.4
1-1/4"	4.13	2.64	2.56	2
1-1/2"	4.72	3.11	2.95	3.3
2"	5.47	3.15	3.31	4.7
2-1/2"	7.13	3.78	4.25	11.6
3"	7.87	4.09	5.39	17

unit:in