

SCHIEBER SCN8112

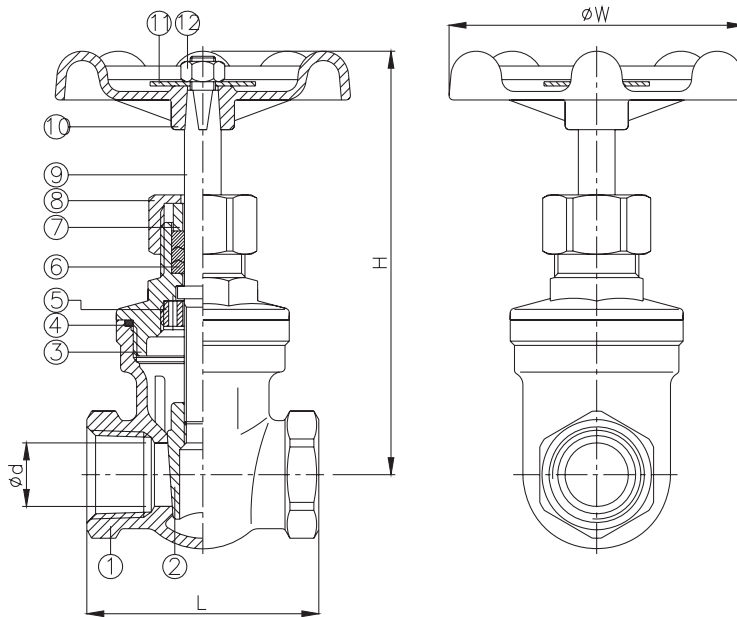

FEATURES

- 1/4"~3" (DN8~DN80)
- W.P. : PN16
- W.T. : -20°C~200°C (-4°F~392°F)
- Investment casting
- Non-rising stem
- Thread type : ISO7/1 & EN10226



ITEM	PARTS	MATERIAL
1	BODY	ASTM A351-CF8M
2	DISC	
3	BONNET	PTFE
4	SEAL	
5	GASKET	AISI 304
6	PACKING	PTFE
7	GLAND RING	AISI 304
8	CAP NUT	ASTM A351-CF8M
9	STEM	AISI 316
10	HANDLE	ALUMINUM
11	NAMEPLATE	
12	NUT	AISI 304

DN	d	L	H	W	Weight (kg)
15	15	55	101	70	0.4
20	20	60	108	70	0.5
25	25	65	118	80	0.7
32	32	75	132	80	1
40	38	85	149	90	1.4
50	50	95	175	100	2.1
65	65	116	213	140	5.8
80	80	130	241	140	8.8

unit:mm

NPS	d	L	H	W	Weight (lb)
1/2"	0.59	2.17	3.98	2.76	1
3/4"	0.79	2.36	4	2.76	1.2
1"	0.98	2.56	4.65	3.15	1.5
1-1/4"	1.26	2.95	5.2	3.15	2.2
1-1/2"	1.5	3.35	5.87	3.54	3.1
2"	1.97	3.74	6.89	3.94	5
2-1/2"	2.56	4.57	8.39	3.94	12.8
3"	3.15	5.12	9.49	5.51	19.4

unit:in